

25Gb/s 1310nm SFP28 10km Transceiver

P/N: WST-S28-LR-x

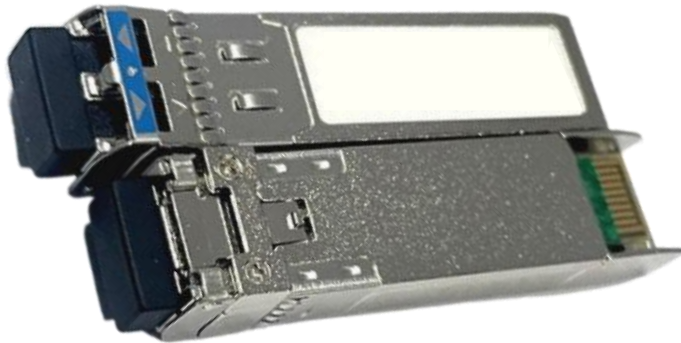

Applications:

- CPRI Option 9&10
- 10G/25G Ethernet

Standard:

- Compliant with SFF-8472
- Compliant to SFF-8431 and SFF-8402e
- Compliant with FCC 47 CFR Part 15, Class B
- Compliant with Telcordia GR-468-CORE
- RoHS Compliant
- Compliant to ITU-T 694.1

Features:

- Support 10.3215G and 25.78Gb/s Data Links
- Up to 10km transmission on SMF
- DML laser transmitter and Pin receiver
- Hot-pluggable form factor
- Duplex LC connector
- RoHS compliant and Lead Free
- Support Digital Diagnostic Monitoring interface.
- Single +3.3V power supply
- Power dissipation < 1.5W
- Case operating temperature
 - Commercial: 0~+70°C
 - Industrial: -40 ~ +85°C

Description

The transceiver is designed for optical communication compliant to CPRI Option 10 · 9 standard ,25G/10GBASE. It is with the SFP+ 20-pin connector to allow hot plug capability. Digital diagnostic functions are available via an I2C. It has built-in clock and data recovery (CDR). This module is designed for single mode fiber and operates at a nominal wavelength of 1310 nm. The transceiver consists of two sections: The transmitter section incorporates a DML laser, and high sensitivity PIN receiver. The module data link up to 10km in 9/125um single mode fiber on both 10G and 25G data rate.

Absolute Maximum Ratings

Parameter	Symbol	Min.	Typ.	Max.	Unit	Note
Storage Temperature	Ts	-40		85	°C	
Relative Humidity	RH	5		85	%	
Power Supply Voltage	VCC	-0.5		4	V	1
Damage Threshold	THd	+5			dBm	

Notes:

1. Non-condensing.
2. Exceeding the limits below may permanently damage the module.

Recommended Operating Conditions

Parameter	Symbol	Min.	Typ.	Max.	Unit	Note
Data Rate	BR	10.3	25.78	26.5	Gbps	
Power Supply Voltage	VCC	3.13	3.3	3.47	V	
Power Supply Current	ICC			450	mA	
Power Dissipation	PD			1.5	W	
Case Operating Temperature	TC	0		+70	°C	
		-40		+85	°C	
Transmission Distance	TD			10	Km	1

Notes:

1. Measured with ITU-T G.652 SMF

Electrical Characteristics

Parameter	Symbol	Min	Typ	Max	Unit	NOTE
Transmitter						
Differential Data Input Amplitude	VIN,P-P	120		800	mVpp	
Input Differential Impedance	ZIN	90	100	110	Ω	1
Transmitter Fault Output-High	VOH	2.0		VCC	V	
Transmitter Fault Output-Low	VOL	0		0.8	V	
Transmitter Disable Voltage- High	VIH	2.0		VCC	V	2
Transmitter Disable Voltage- low	VIL	0		0.8	V	
Transmit Disable Assert Time	Tdesser			10	us	
Receiver						
Differential output voltage swing	VOUT,P-P	340		800	mVpp	3
Output Differential Impedance	ZOUT	90	100	110	Ω	
Data output rise/fall time	Tr/Tf	28			ps	4
Power Supply Rejection	PSR	100			mVpp	6
LOS Output Voltage-High	VLOSH	2.0		VCC	V	5
LOS Output Voltage-Low	VLOSL			0.8	V	5

Notes:

- 1.AC coupled.
- 2.Or open circuit.
- 3.Into 100-ohm differential termination.
- 4.20 – 80 %
- 5.LOS is LVTTTL. Logic 0 indicates normal operation; logic 1 indicates no signal detected.
- 6.All transceiver specifications are compliant with a power supply sinusoidal modulation of 20 Hz to 1.5MHz up to specified value applied through the power supply filtering network shown on page 23 of the Small Form-factor Pluggable (SFP) Transceiver Multi-Source Agreement (MSA), September 14, 2000.

Optical Characteristics

Parameter	Symbol	Min	Typ	Max	Unit	NOTE
Transmitter						
Optical Center Wavelength	λ_C	1295	1310	1320	nm	
Average Output Power	PO	-5		2	dBm	1
Optical Extinction Ratio	ER	3.5			dB	
RMS Spectral Width	σ			1	nm	
Side Mode Suppression Ratio	SMSR	30			dB	
Optical Rise/Fall Time	Tr/Tf			260	ps	2
Transmitter and Dispersion Penalty	TDP			3.2	dB	
Eye Mask Coordinates: X1, X2,X3, Y1, Y2, Y3 [4]	{0.31, 0.4, 0.45, 0.34, 0.38, 0.4}					
Receiver						
Center Wavelength Range	λ_C	1260		1610	nm	
Receiver Sensitivity(OMA)	RSEN			-13	dBm	3
Input Saturation Power (overload)	Psat	0.5			dBm	
LOS Assert	LOSA	-30			dBm	
LOS De-Assert	LOSD			-15	dBm	
LOS Hysteresis	LOSH	0.5			dB	

Notes:

- 1.The optical power is launched into SMF
- 2.20-80%
- 3.Measured with a PRBS 2³¹-1 test pattern,25.78G@BER=5E-5 and 10.3125G@BER=1E-12
- 4.Jitter measurements taken using Agilent OMNIBERT 718 in accordance with GR-253

Pin Assignment

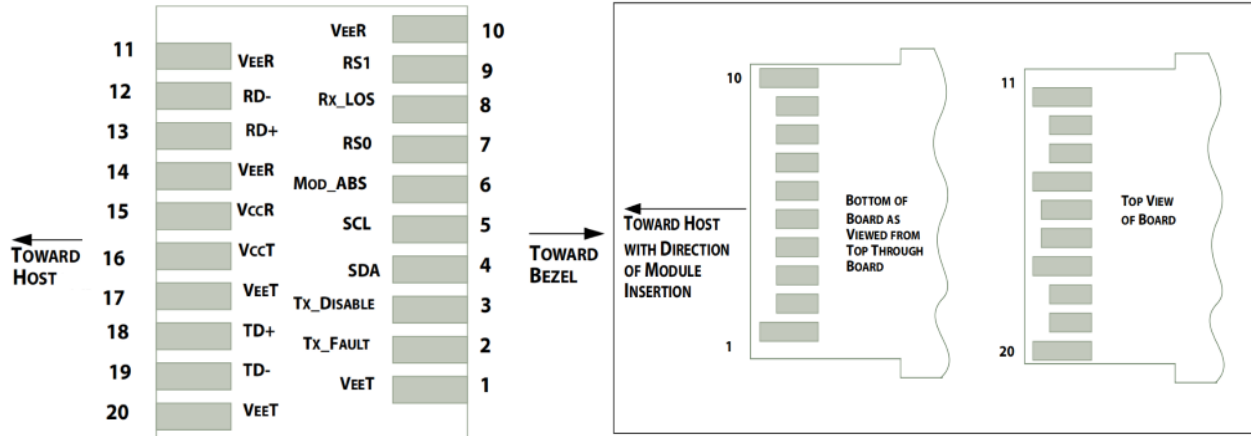

Host PCB SFP+ pad assignment top view and Names.

Pin	Symbol	Name/Description	NOTE
1	VEET	Module Transmitter Ground	1
2	Tx_Fault	Module Transmitter Fault	2
3	Tx_Disable	Transmitter Disable, Turns off transmitter laser output	3
4	SDA	2 wire serial interface data input/output (SDA)	4
5	SCL	2 wire serial interface clock input (SCL)	4
6	MOD_ABS	Module Absent, connected to VeeT or VeeR in the module	4
7	RS0	Receiver Rate Select 0	5
8	Rx_LOS	Loss of Signal indication, Logic 0 indicates normal operation	6
9	RS1	Transmitter Rate Select, Not Used for this Product	
10	VEER	Module Receiver Ground	1
11	VEER	Module Receiver Ground	1
12	RD-	Receiver Inverted Data Output, AC Coupled	
13	RD+	Receiver Non- Inverted Data Output, AC Coupled	
14	VEER	Module Receiver Ground	1
15	VCCR	Module Receiver 3.3V Supply	
16	VCCT	Module Transmitter 3.3V Supply	
17	VEET	Module Transmitter Ground	1
18	TD+	Transmitter Non-Inverted Data Input, AC Coupled	
19	TD-	Transmitter Inverted Data Input, AC Coupled	

20	VEET	Module Transmitter Ground	1
----	------	---------------------------	---

Notes:

1. Circuit ground is internally isolated from chassis ground.
2. TFAULT is an open collector/drain output, which should be pulled up with a 4.7kΩ-10kΩ resistor on the host board if intended for use. Pull up voltage should be between 2.0V to Vcc + 0.3V. A high output indicates a transmitter fault caused by either the TX bias current or the TX output power exceeding the preset alarm thresholds. A low output indicates normal operation. In the low state, the output is pulled to <0.8V.
3. Laser output disabled on TDIS >2.0V or open, enabled on TDIS <0.8V.
4. Should be pulled up with 4.7kΩ-10kΩ on host board to a voltage between 2.0V and 3.6V. MOD_ABS pulls line low to indicate module is plugged in.
5. Internally pulled down per SFF-8431 Rev 4.1.
6. LOS is open collector output. It should be pulled up with 4.7kΩ-10kΩ on host board to a voltage between 2.0V and 3.6V. Logic 0 indicates normal operation; logic 1 indicates loss of signal.

Digital Diagnostic and Memory Map

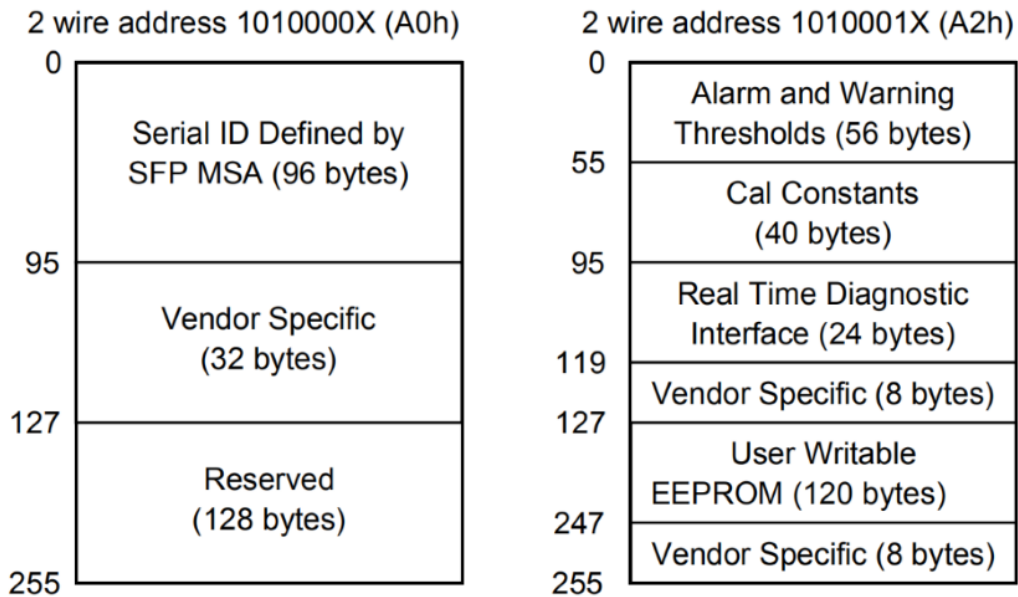

Digital Diagnostic Monitor Characteristics

Parameter	Calibration	Range	Accuracy	Unit
Transceiver Internal Temperature	Internal	-40 to +85°C	±3.0	°C
Vcc3 Internal Supply Voltage	Internal	3.0 to 3.6V	±3.0	%
Laser Bias Current	Internal	0 to 80mA	±10	%
Tx Output Power	Internal	-8 to 5dBm	±3.0	dBm
Rx Input Power	Internal	-16 to 0dBm	±3.0	dBm

Host - Transceiver Interface Block Diagram

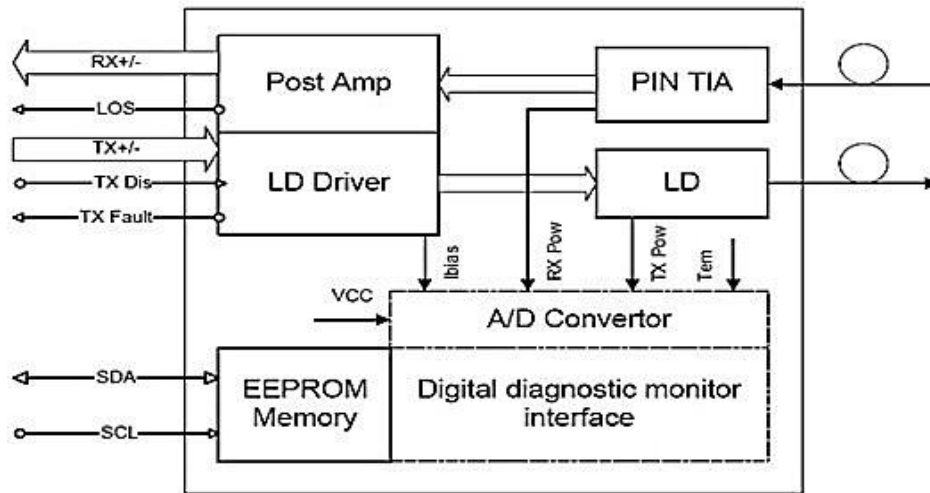

Mechanical Drawing

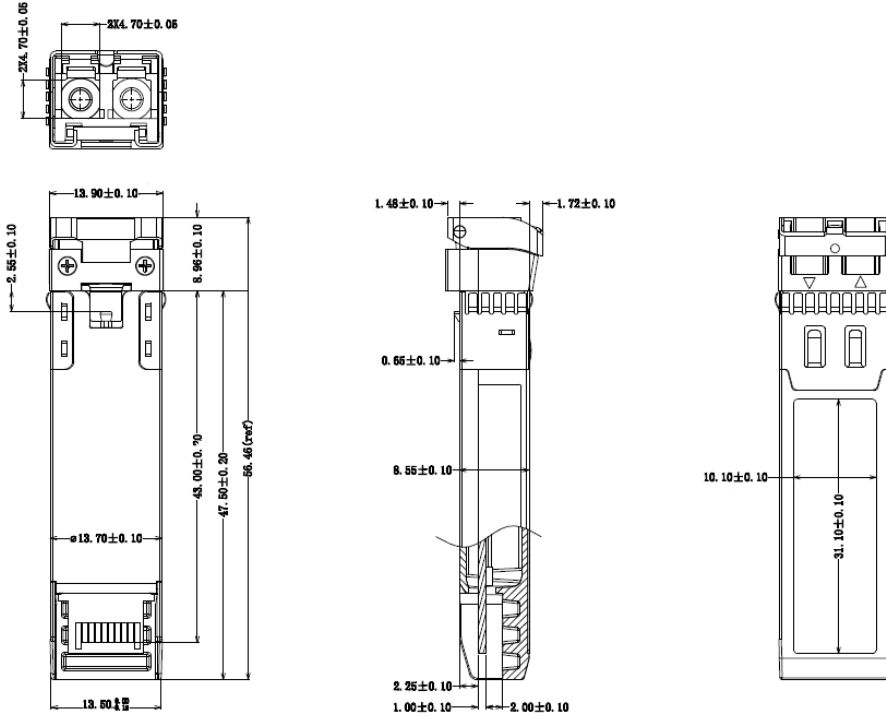

Unit:

Ordering Information

Part No	Specification									
	Package	Data rate per Lane	Laser	Optical Power	Detector	Max. Receive Sensitivity (OMA)	Temp	Reach	Other	Application code
WST-S28-LR-C	SFP28	25.78 Gbps each Channel	1310nm DFB	-5~ +2 each Channel	PIN	-13 dBm each Channel	0~70°C	10km	DDM RoHS	10G/25G Ethernet
WST-S28-LR-I	SFP28	25.78 Gbps each Channel	1310nm DFB	-5~ +2 each Channel	PIN	-13 dBm each Channel	-40~85°C	10km	DDM RoHS	10G/25G Ethernet

Modification History

Revision	Date	Description	Originator	Review	Approved
V1.0	07-Aug-2024	New Issue	Ken Cheng	Joanne Ni	Tom Tang

**Headquarters**

16F-5, No. 75, Sec. 1, Xintai 5th Rd., Xizhi Dist.,
 New Taipei City 22101, Taiwan
 Tel: +886-2-2698-7208
 Fax: +886-2-2698-7210
 Email: sales@wavesplitter.com
 Website: <https://wavesplitter.com/>