

## 40G QSFP+ SR4 Transceiver

P/N: WST-QSFP+SR4-C



### Features:

- Support 40GBASE-SR4/QDR application
- Compliant to QSFP+ Electrical MSA SFF-8436
- Multi rate of up to 10.3125Gbps
- Transmission distance up to 150m (OM3)
- +3.3V single power supply
- Low power consumption
- Operating case temp Commercial: 0°C to +70 °C
- RoHS compliant

### Applications:

- 40GBASE-SR4 at 10.3125Gbps per lane
- InfiniBand QDR
- Other optical links

### Absolute Maximum Ratings

Parameter	Symbol	Min.	Typical	Max.	Unit	Notes
Supply Voltage	V <sub>CC3</sub>	-0.5	-	+3.6	V	
Storage Temperature	T <sub>s</sub>	-10	-	+85	°C	
Operating Humidity	RH	+5	-	+85	%	1
Receiver Damage Threshold per Lane	P <sub>IND</sub>	+4	-	-	dBm	

Note:

- 1 No condensation

**Recommended Operating Conditions**

Parameter	Symbol	Min.	Typical	Max.	Unit	Notes
Operating Case Temperature	T <sub>C</sub>	0	-	+70	°C	
Power Supply Voltage	V <sub>CC</sub>	3.14	3.3	3.47	V	
Power Dissipation	P <sub>d</sub>	-	-	1.5	W	
Bit Rate	BR	1.25	10.3125	-	Gbps	

**Electrical Characteristics**

Parameter	Symbol	Min.	Typ.	Max.	Units	Notes
Input Logic Level High	V <sub>IH</sub>	2.5	-	V <sub>CC</sub> +0.3	V	
Input Logic Level Low	V <sub>IL</sub>	0	-	0.8	V	
Output Logic Level High	V <sub>OH</sub>	2.4	-	V <sub>CC</sub>	V	
Output Logic Level Low	V <sub>OL</sub>	0	-	0.4	V	
<b>Transmitter</b>						
Differential Data Input Swing	V <sub>in,P-P</sub>	200	-	1600	mV <sub>PP</sub>	
Input Differential Impedance	Z <sub>IN</sub>	80	100	120	Ω	
<b>Receiver</b>						
Differential Data Output Swing	V <sub>out</sub>	350	-	1000	mV	
Output Differential Impedance	Z <sub>D</sub>	80	100	120	Ω	

**Optical Characteristics**

Parameter	Symbol	Unit	Min	Typ	Max	Notes
<b>Optical transmitter Characteristics</b>						
Bit Rate	BR	Gbps	1.25	10.3125	-	
Center Wavelength Range	$\lambda_c$	nm	830	850	870	
RMS Spectral Width	$\Delta\lambda$	nm	-	-	0.65	
Average Launch power Tx_off	P <sub>off</sub>	dBm	-	-	-30	
Launch Optical Power	P <sub>0</sub>	dBm	-6.0			1
Extinction Ratio	ER	dB	3	-	-	
<b>Optical Receiver Characteristics</b>						
Bit Rate	BR	Gbps	1.25	10.3125	-	
Sensitivity@BER=E-12	BER	dBm	-	-	-10.2	
Overload Input Optical Power	P <sub>IN</sub>	dBm	2.5	-	-	2
Center Wavelength Range	$\lambda_c$	nm	820	-	880	
LOS Assert	-	dBm	-30	-	-	
LOS De-Assert	-	dBm	-	-	-12	
LOS Hysteresis	-	dB	0.5	-	-	

## Notes:

1. Coupled into 50/125 MMF.
2. Measured with PRBS 2<sup>31</sup>-1 test pattern @10.3125Gbps.BER=E-12

**Pin Assignment**

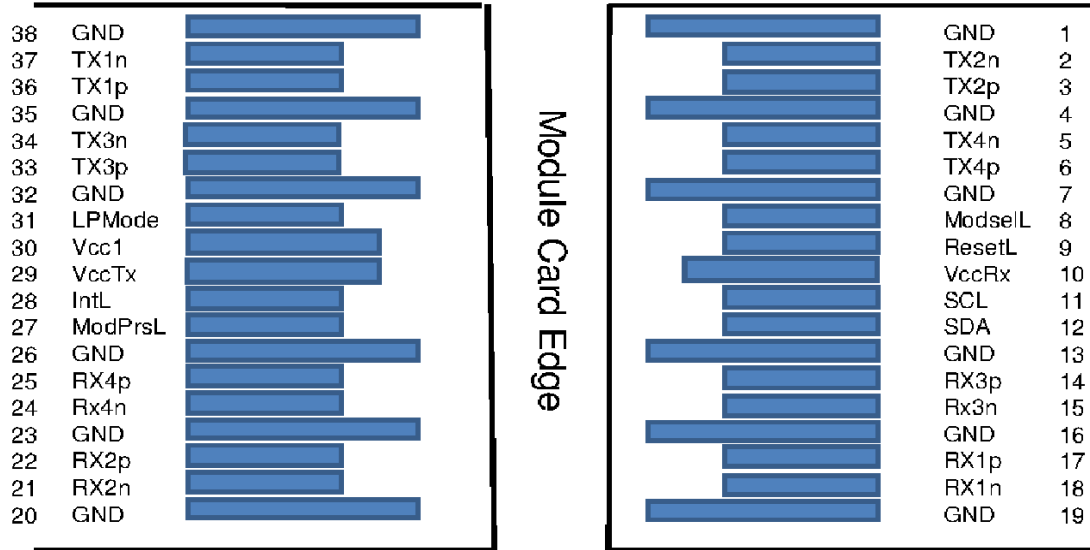

**Top Side  
Viewed From Top**

**Bottom Side  
Viewed From Bottom**

**Pin out of Connector Block on Host Board**

Pin	Symbol	Name/Description	Notes
1	GND	Ground	1
2	Tx2n	Transmitter Inverted Data Input	
3	Tx2p	Transmitter Non-Inverted Data Input	
4	GND	Ground	1
5	Tx4n	Transmitter Inverted Data Input	
6	Tx4p	Transmitter Non-Inverted Data Input	
7	GND	Ground	1
8	ModSelL	Module Select	
9	ResetL	Module Reset	
10	Vcc Rx	+3.3V Power Supply Receiver	
11	SCL	2-wire serial interface clock	
12	SDA	2-wire serial interface data	
13	GND	Ground	1
14	Rx3p	Receiver Non-Inverted Data Output	
15	Rx3n	Receiver Inverted Data Output	
16	GND	Ground	1
17	Rx1p	Receiver Non-Inverted Data Output	

18	Rx1n	Receiver Inverted Data Output	
19	GND	Ground	1
20	GND	Ground	1
21	Rx2n	Receiver Inverted Data Output	
22	Rx2p	Receiver Non-Inverted Data Output	
23	GND	Ground	1
24	Rx4n	Receiver Inverted Data Output	
25	Rx4p	Receiver Non-Inverted Data Output	
26	GND	Ground	1
27	ModPrsL	Module Present	
28	IntL	Interrupt	
29	Vcc Tx	+3.3V Power supply transmitter	
30	Vcc1	+3.3V Power supply	
31	LPMODE	Low Power Mode	
32	GND	Ground	1
33	Tx3p	Transmitter Non-Inverted Data Input	
34	Tx3n	Transmitter Inverted Data Input	
35	GND	Ground	1
36	Tx1p	Transmitter Non-Inverted Data Input	
37	Tx1n	Transmitter Inverted Data Input	
38	GND	Ground	1

## Note:

1. Circuit ground is internally isolated from chassis ground.

**Recommended Host - Transceiver Interface Block Diagram**

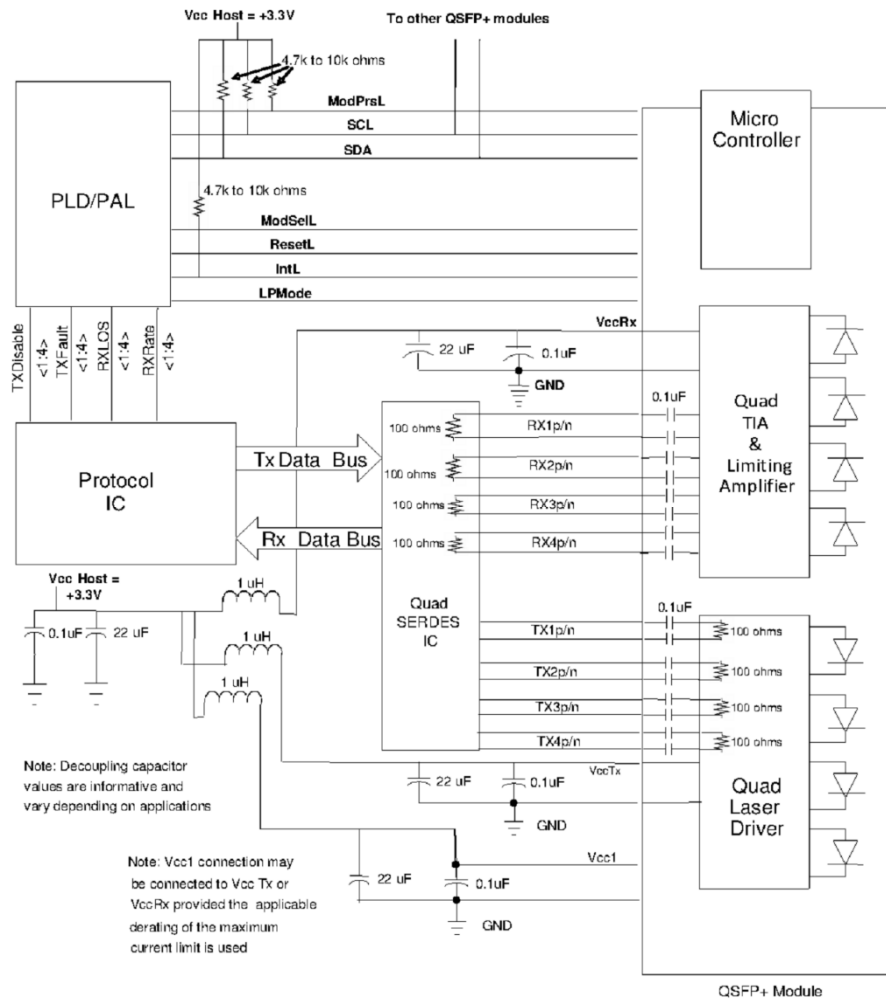

**Optical interface arrangement**

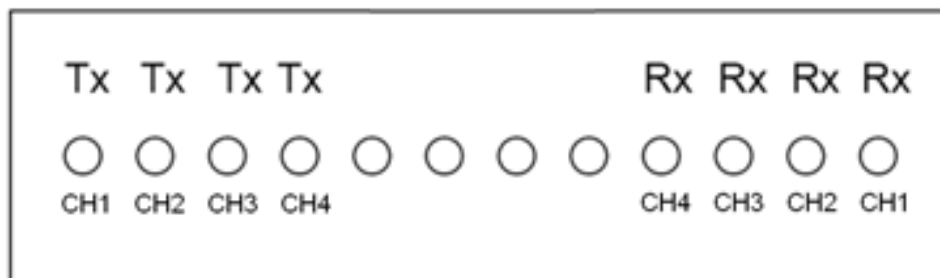

**Recommended Typical Application Circuit**

**Memory map**

2-Wire Serial Address 1010000x	
Lower Page 00h	
0	Identifier
1- 2	Status
3- 21	Interrupt Flags
22- 33	Free Side Device Monitors
34- 81	Channel Monitors
82- 85	Reserved
86- 98	Control
99	Reserved
100-104	Hardware Interrupt Pin Masks
105-106	Vendor Specific
107	Reserved
108-110	Free Side Device Properties
111-112	Assigned for use by PCI Express
113	Free Side Device Properties
114-118	Reserved
119-122	Password Change Entry Area (Optional)
123-126	Password Entry Area (Optional)
127	Page Select Byte

Upper Page 00h	Optional Page 01h	Optional Page 02h	Optional Page 03h	
128 Identifier	128 CC_APPS	128-255 User EEPROM Data	128-175 Free Side Device Thresholds	
129-191 Base ID Fields	129 AST Table Length (TL)		176-223 Channel Thresholds	224 Tx EQ & Rx Emphasis Magnitude ID
	130-131 Application Code Entry 0			
	132-133 Application Code Entry 1			
134-253 other entries	225 RX output amplitude indicators			
192-223 Extended ID		226-241 Channel Controls		
224-255 Vendor Specific ID		242-251 Channel Monitor Masks		
		252-255 Reserved		
	254-255 Application Code Entry TL			

**Mechanical Drawing**

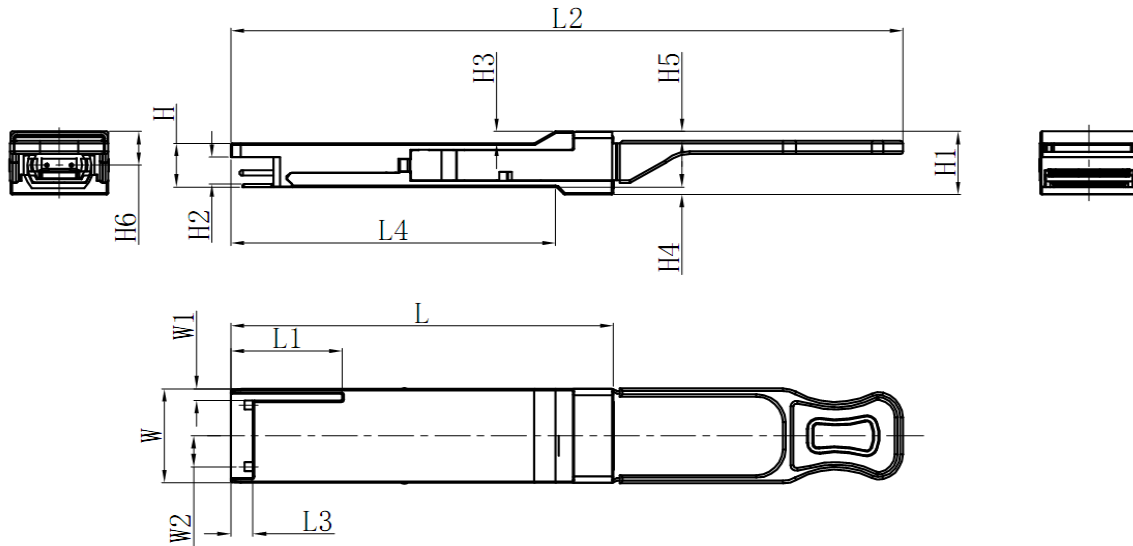

Unit mm

	L	L1	L2	L3	L4	W	W1	W2	H	H1	H2	H3	H4	H5	H6
Max	72.2	-	128	4.35	61.4	18.45	-	6.2	8.6	12.4	5.35	2.5	1.6	2.0	-
Type	72.0	-	-	4.20	61.2	18.35	-	-	8.5	12.2	5.2	2.3	1.5	1.8	6.55
Min	68.8	16.5	124	4.05	61.0	18.25	2.2	5.8	8.4	12.0	5.05	2.1	1.3	1.6	-

**Ordering Information**

Part No	Specification									
	Package	Data rate per Lane	Laser	Optical Power	Detector	Max. Receive Sensitivity (OMA)	Temp	Reach	Other	Application code
WST-QSFP+SR4-C	QSFP	10.3125Gbps each Channel	850nm	3.14~ 3.47 each Channel	PIN	-10.2dBm each Channel	0~70°C	150m	DDM RoHS	40GBASE-SR4/QDR

**Modification History**

Revision	Date	Description	Originator	Review	Approved
V1.0	23-Jul-2020	New Issue	Elma Yueh	Wayne Liao	Wayne Liao



**Taipei Headquarters**  
 16F-5, No. 75, Sec. 1,  
 Xintai 5th Rd., Xizhi Dist.,  
 New Taipei City 22101,  
 Taiwan  
 Tel: +886-2-2698-7208  
 Fax: +886-2-2698-7210

**U.S. Branch**  
 2080 Rancho Higuera Ct.  
 Fremont, CA 94539,  
 USA  
 Tel: 510-651-7800  
 Fax: 510-651-7822

**ShenZhen Branch**  
 610#, 6F, No.204 Building,  
 2nd Industrial zone  
 Nanyou, Nanshan district,  
 Shenzhen, Guangdong  
 China 518054  
 Tel: +86-755-86265980  
 Fax: +86-755-26642741

All specification data are accurate on the date of publication for product comparisons and ordering information. WaveSplitter Technologies, Inc. reserves the right to change specifications without notice.